

KVA	OIL Litres	UNTANKING MASS kg	TOTAL kg
300	620	780	1855

ITEM	DESCRIPTION
1	HV 11kV TWO PIECE CABLE BOX BUSHING 160A
2	LV BUSHING 415V ESAA No.72 500A
3	TAPSWITCH HANDLE & LOCKING BRACKET
4	RATING PLATE
5	OIL GAUGE
6	LIFTING LUG
7	EARTH STUD M12 STAINLESS STEEL
8	HV COMPARTMENT
9	LV COMPARTMENT
10	COOLING RADIATORS
11	FILLER & FILTER SOCKET 25NB
12	DRAIN VALVE 25NB
13	COMPARTMENT SEGREGATION

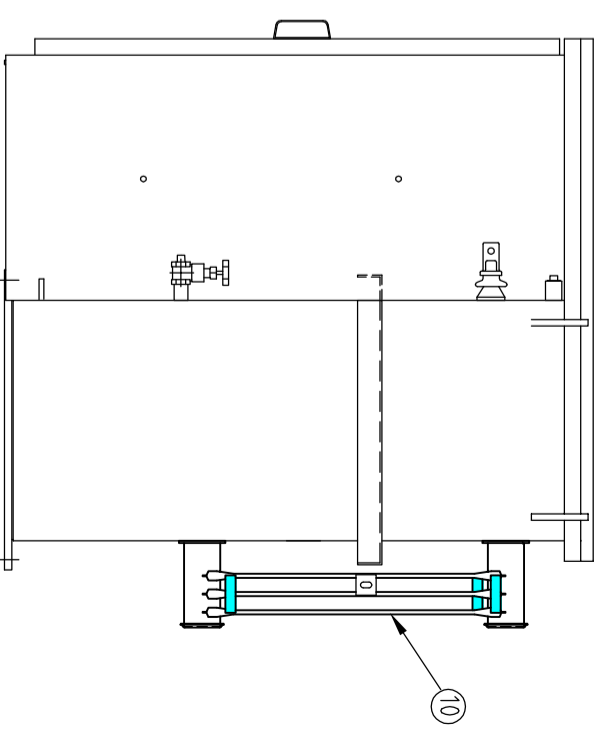
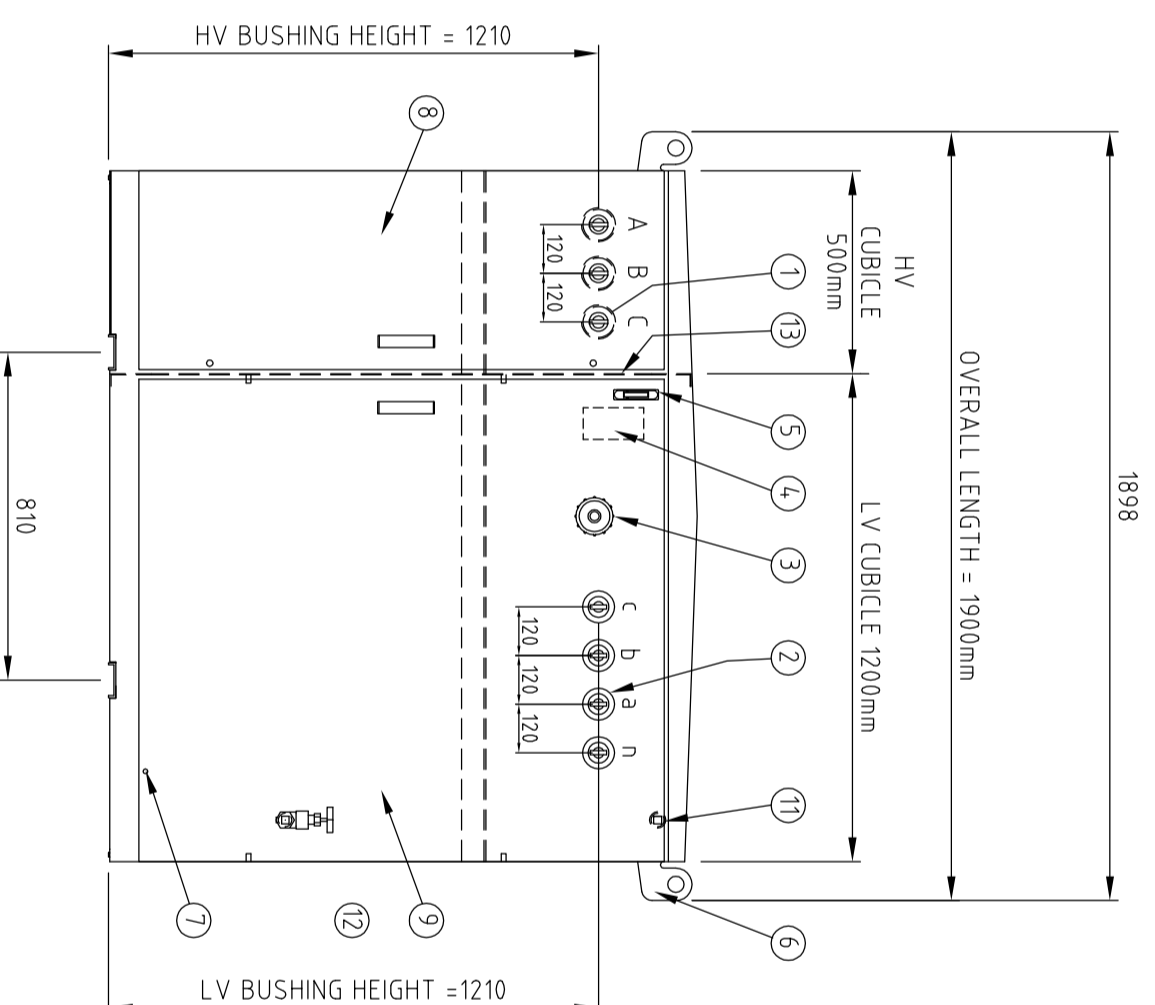
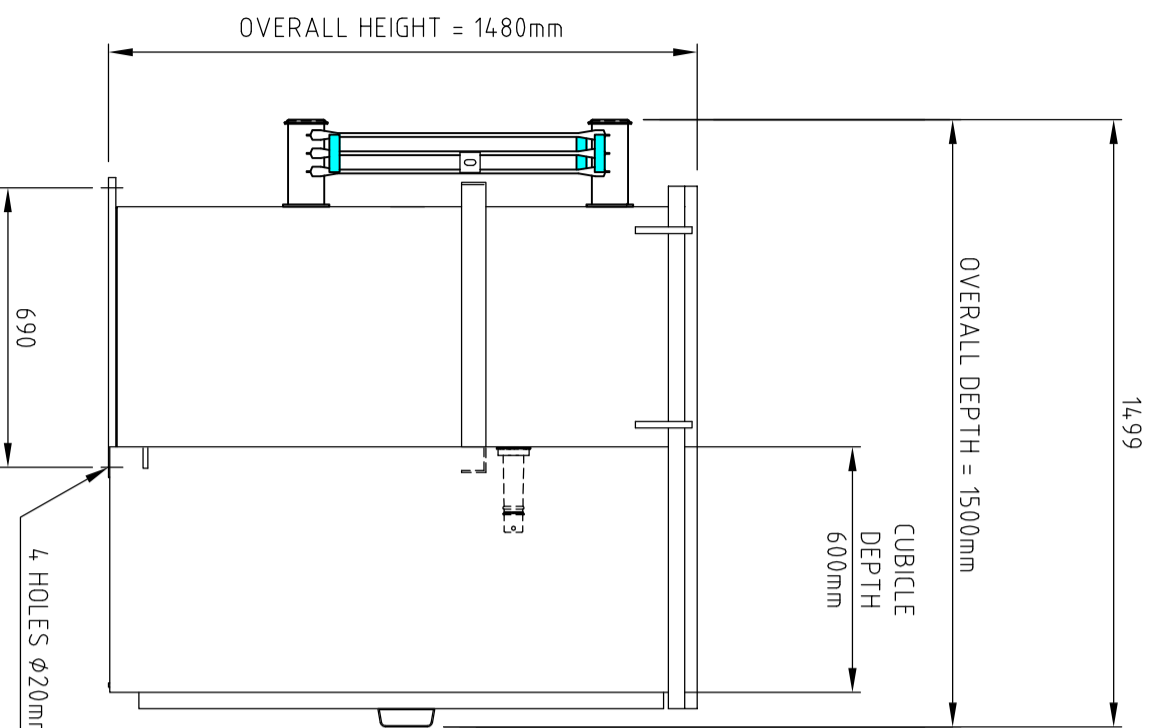

REV	DESCRIPTION	DRAWN	DATE	APPD.	DRAWN	DATE
B	STIFFENERS UPDATED	A.R.	6 AUG 15		JAYESH	20 AUG 2012
C	TAPSWITCH REPLACED	JS	20 AUG 18	M.Z	VIRGILIO	20 AUG 2012
						SCALE 1=20
						TOLERANCE +/- 2mm

**GENERAL ARRANGEMENT**

300kVA 3Ø 11kV/415-240V Dyn11  
 FRONT ACCESS KIOSK TRANSFORMER  
 HV CUBICLE 600mm DEEP & 500mm WIDE  
 LV CUBICLE 600mm DEEP & 1200mm WIDE

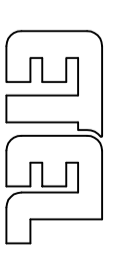

Distribution Transformers

DRAWING No. **039.904.0748** REV **C**

904.0300.3602