

1 2 3 4 5 6 7 8 9 10

A
B
C
D
E
F
G
H

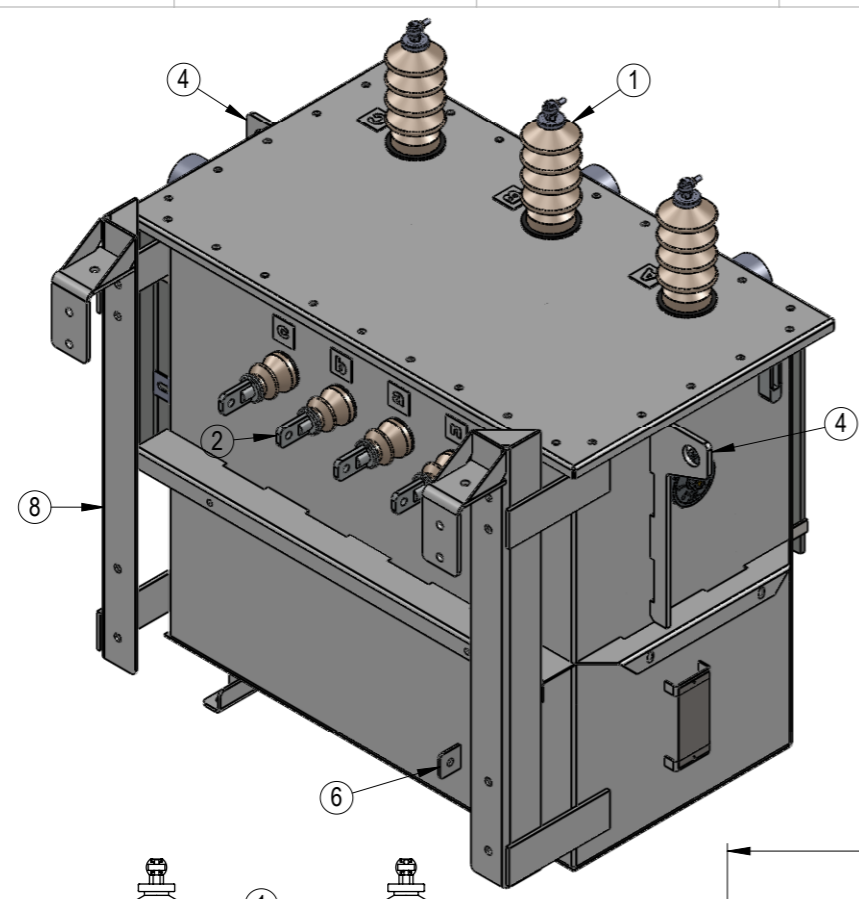

APPROXIMATE MASSES	kg
OIL 305 litre	268
UNTANKING MASS	450
TOTAL	955

ITEM	DESCRIPTION
1	HV BUSHING 12kV, No75 30A -4 SHED EYEBOLT
2	LV BUSHING -3.6kV No72 200A
3	RATING PLATE
4	LIFTING LUG
5	OIL LEVEL SIGHT GLASS
6	EARTH TERMINAL -STAINLESS STEEL
7	TAPSWITCH </td
8	CROSSARM HANGER ASSY
9	RADIATOR

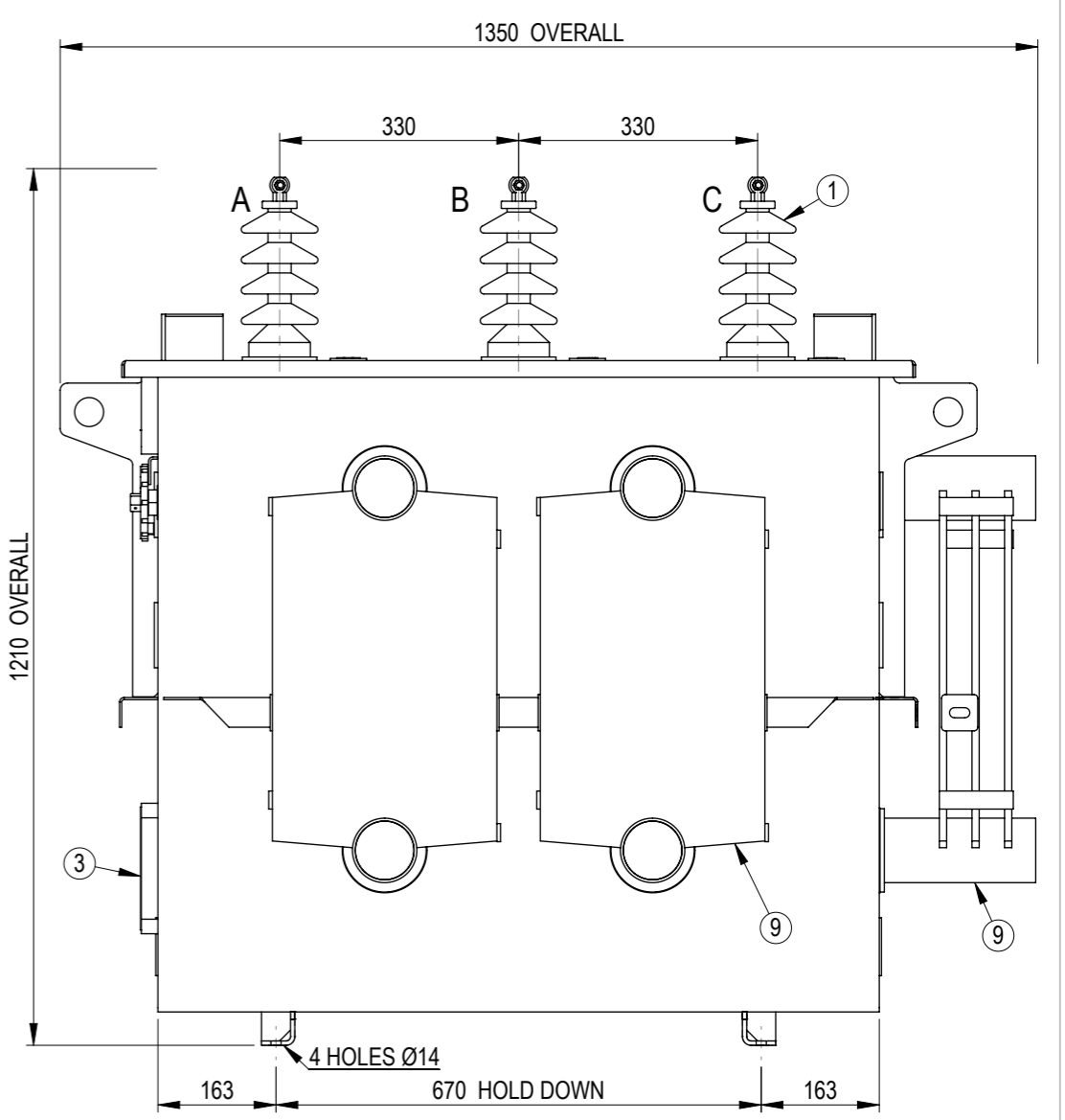
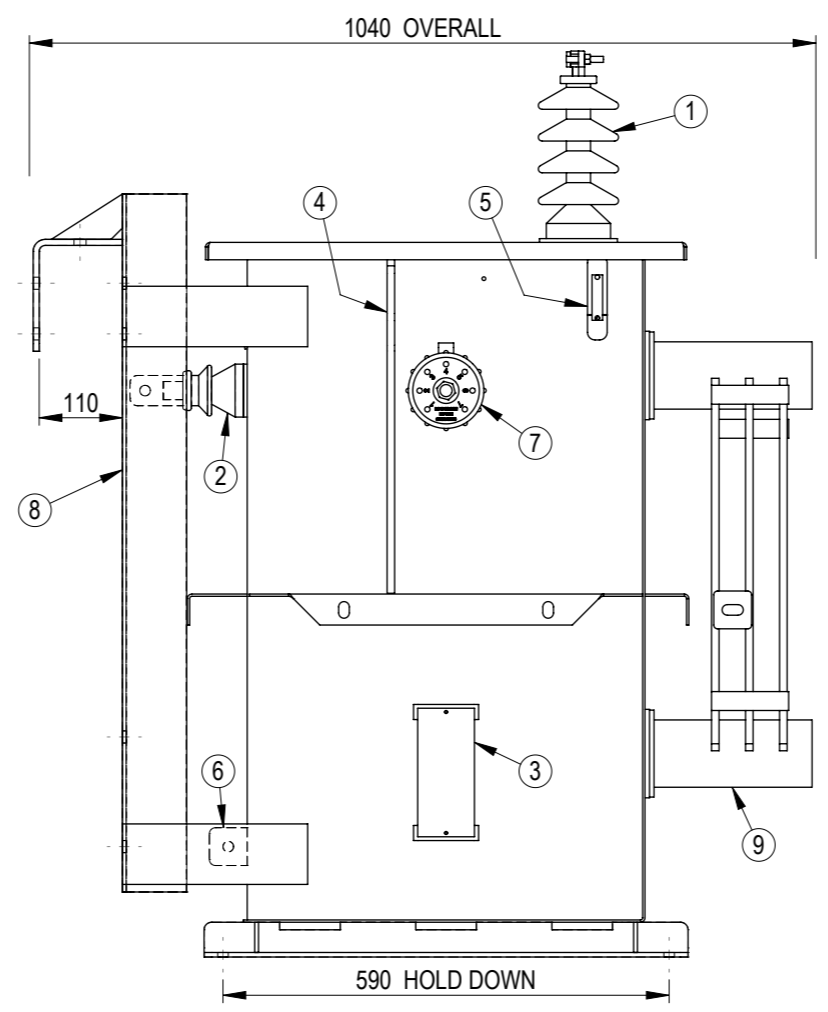
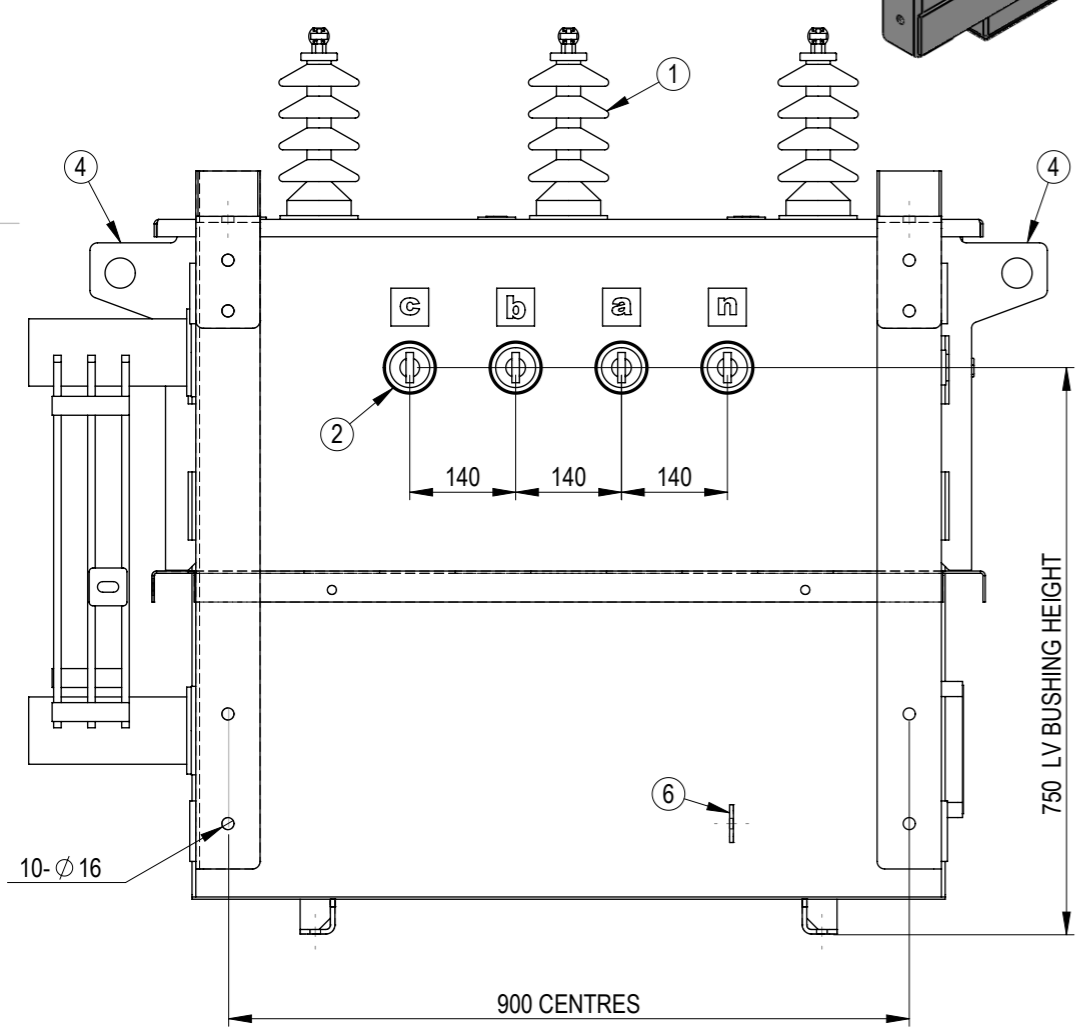

NAME	SIGNATURE	DATE	SCALE AT A3 = 1:10	TITLE:
DRAWN	AR	16/03/2016		GENERAL ARRANGEMENT 150kVA TRANSFORMER POLE CROSSARM 3PH 11000/415-240V Dyn11
CHECKED	VZ	16/03/2016		
APPROVED	VZ	16/03/2016		
WEIGHT: -kg		FINISH: -	UNLESS SPECIFIED: DIMENSIONS ARE IN mm	
MATERIAL: -		TOLERANCES: LINEAR: X = ± 1 .X = ± 0.5 .XX = ± 0.1		ANGULAR: X = ± 0.5°

Copyright © ETEL Limited. All rights reserved.
 No part of this document may be reproduced nor information contained hereon divulged to third parties without written consent from ETEL Limited.



Distribution Transformers

REV	DESCRIPTION	AUTHORITY	DRAWN	DATE	APPD	DATE
A	INITIAL RELEASE	CUSTOMER REQUEST	AR	16/03/16	VZ	16/03/16

REVISION INFORMATION

SHEET	DWG NO.	REV.
1 OF 1	904.0150.3001	A